

Supplement/Craft
1 copy for each child

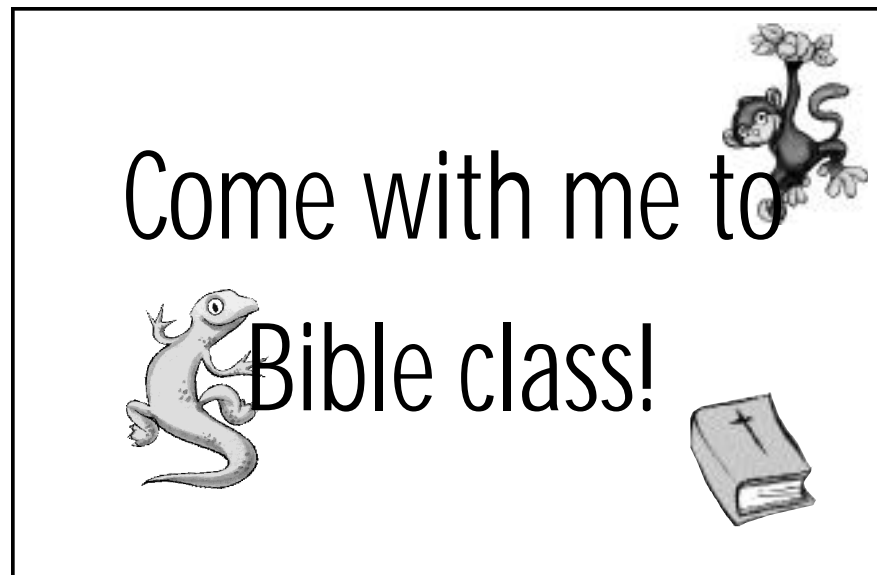

invitation

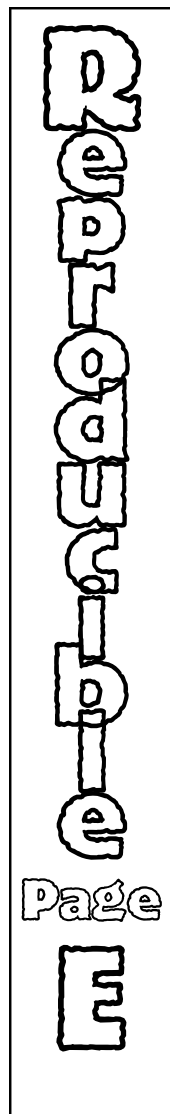

Supplement/Craft
1 copy for each child

Jesus Is Born
Lesson 1

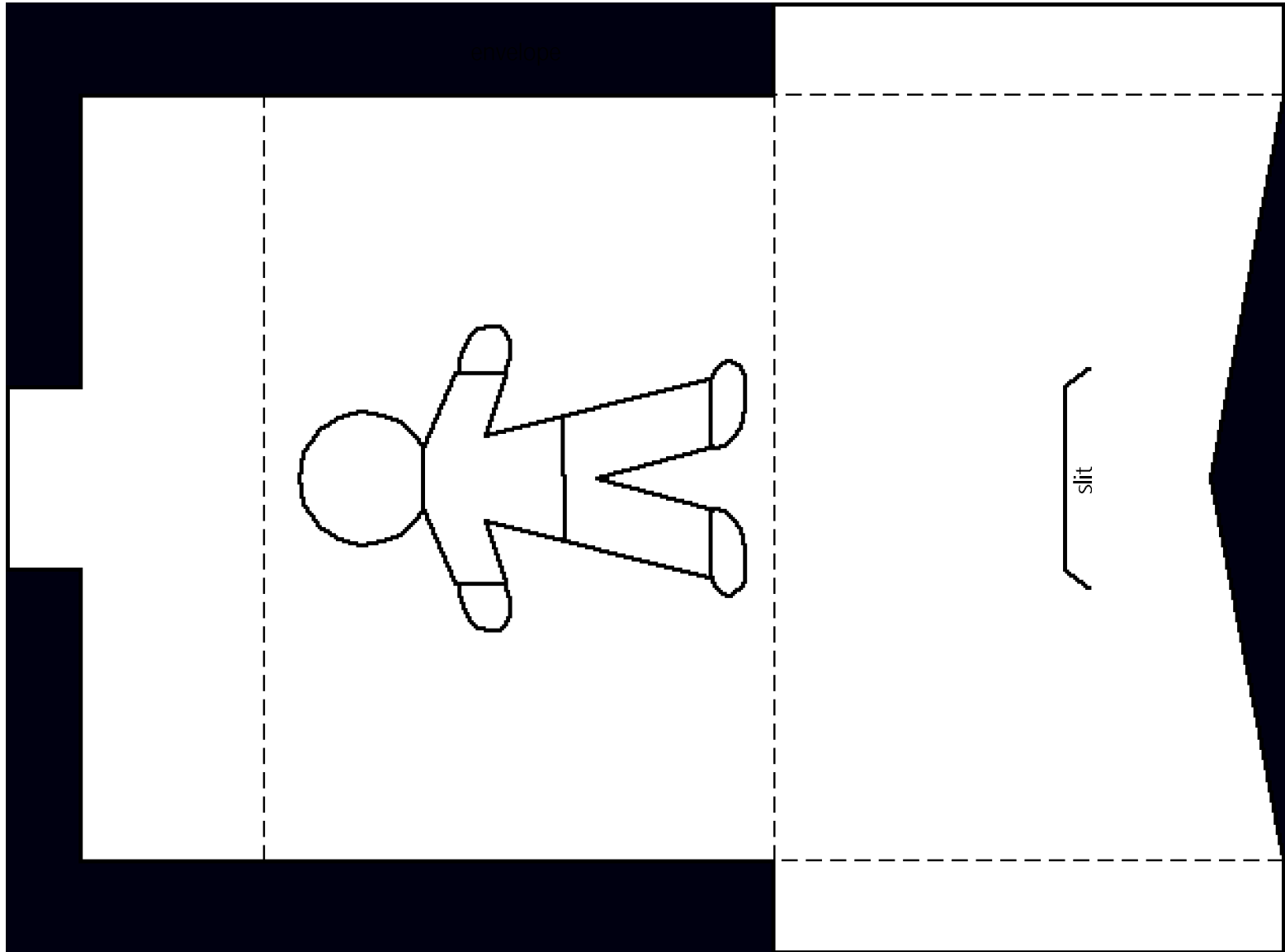

Supplement/Game
1 copy for the teacher

Jesus Is Born
Lesson 1

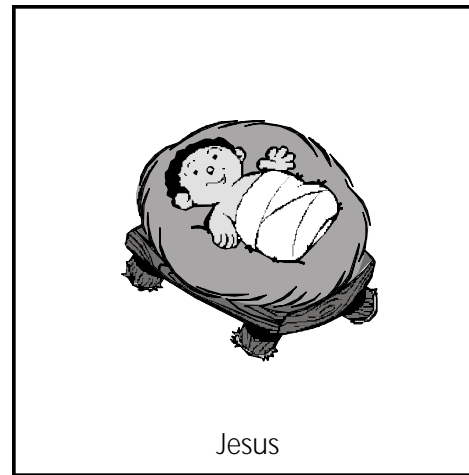
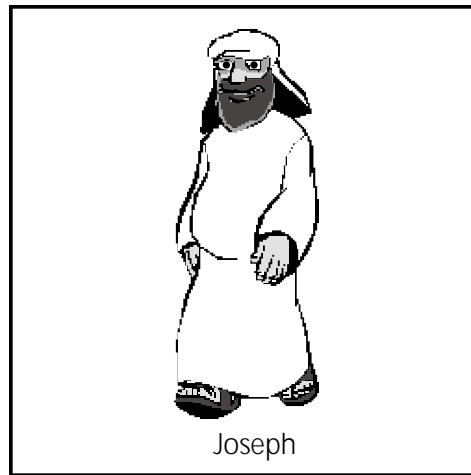
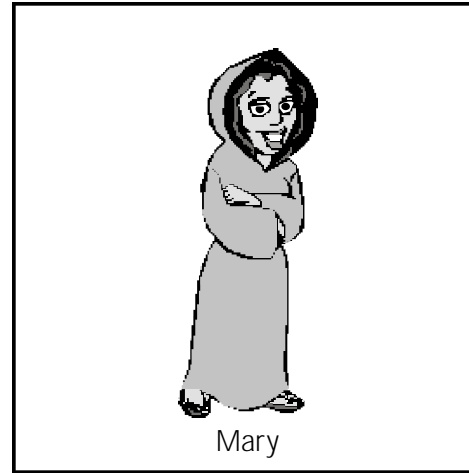
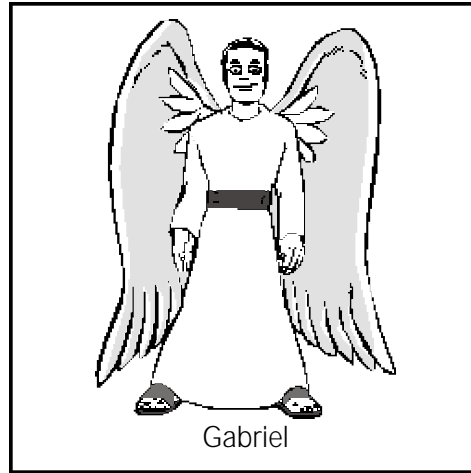

Core and Supplement/Life Application
1 copy for the teacher



whiny weasel



wise owl



Core/Preclass
1 copy for the teacher

Jesus Is Born
Lesson 1

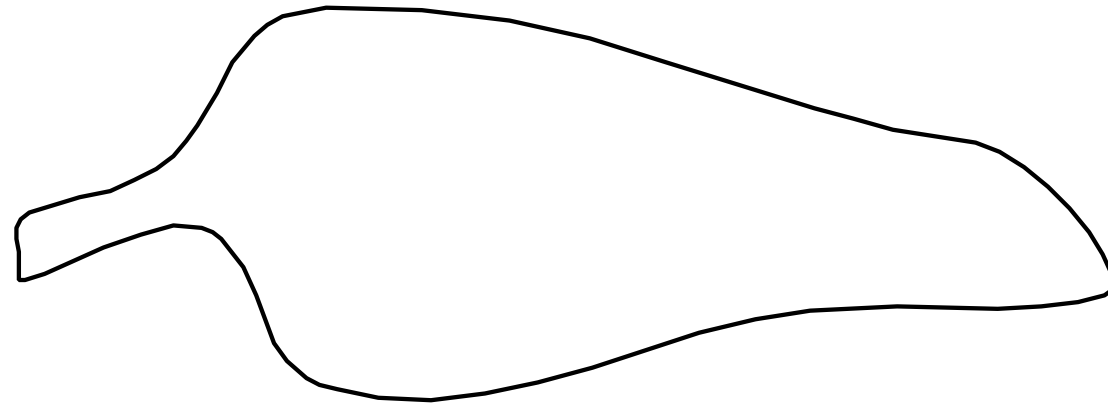

feather stencil



supplement

Life

APPLICATION

Mary and Joseph

Jesus Is Born

Lesson 1



Winter 2

© 1999 by Discipleship Publications International

Jesus Is Born 13-1-14



Mary and Joseph

Jesus Is Born

Lesson 1

Whiny or Wise

The children will learn that God is happy when they are happy and do not complain.

Scripture Memory Verse

"This is my Son, whom I love; with him I am well pleased."

Matthew 3:17

Materials

For the Teacher:

- 2 craft sticks
- markers
- glue stick

Reproducible Pages:

- Page B, 1 copy for the teacher

Preparation

1. Cut out and color the puppets from the copy of Reproducible Page B.
2. Glue each puppet onto a craft stick.
3. Familiarize yourself with the scenes.

Instructions

Discuss Mary's happy obedience with the children. Today we are learning about Mary. She didn't grumble or complain when the angel came to visit her. She could have been so disappointed and whiny when the angel came to tell her that she was going to have a baby. Instead she trusted God and was happy. Today Weasel and Owl are going to visit us and I want you to see how they are doing with grumbling and complaining.

Scene 1

OWL: Come on, Weasel, hold my hand while we walk across the street.

WEASEL: (in a very whiny voice) Why should I? I'm big. I don't need to hold your hand.

TEACHER: Do you think Weasel is being like Mary? Why not? How should Weasel answer owl? (Discuss correct responses.)

Scene 2

OWL: Come on, Weasel, Mom said for us to clean our rooms before our friends come over.

WEASEL: (in a very whiny voice) But, I want to finish watching this TV show. I never get to watch TV and I always have to clean my room. Why do we have to keep our rooms so clean?

TEACHER: What do you think about Weasel's answer? How should he act? What should he say? Now let's see how Weasel and Owl are doing playing baseball.

Scene 3

OWL: Hey, Weasel! You're out! That was your third strike!

WEASEL: No, that was a bad pitch. You always make me get out. I never get to be at bat for very long.

OWL: Weasel, you've got to learn to be a good sport and follow the rules.

WEASEL: Why do we have to have all these silly rules? You try to make me strike out all the time.

TEACHER: Do you think Weasel was being a good sport? How should he act when he's playing baseball?

Scripture Memory Activity

Tell the children the memory scripture. Ask the children whom they think the scripture talks about. Discuss the scripture with them. Have the children repeat the scripture with you a few times.

Conclusion

Choose a child to pray and ask God to help the class to be happy and obedient. Have them thank God for the gift of Jesus.

Ask the children with whom they might share what they are learning.

Teacher Tips

- Add any other scenes that may pertain to the cultural and social needs of your congregation.

supplement

CRAFT

Mary and Joseph

Jesus Is Born

Lesson 1

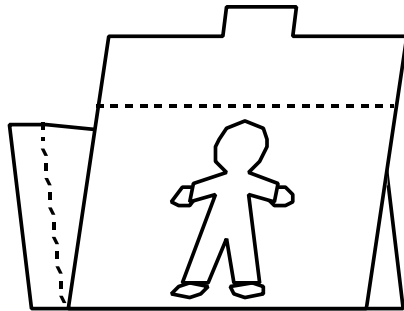

Figure A

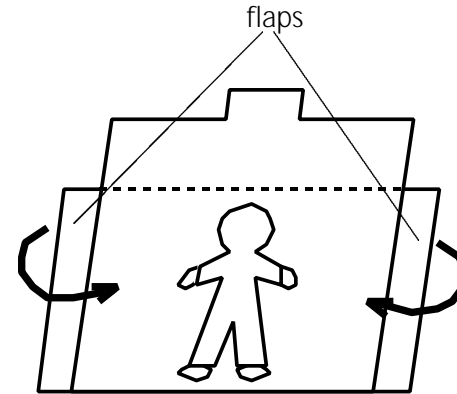
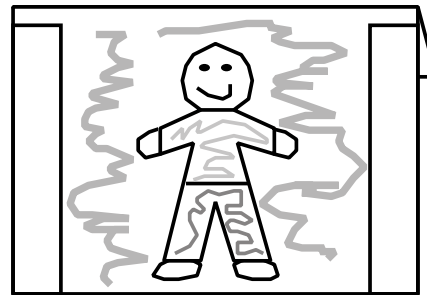

Figure B



Finished Craft



CRAFT



Mary and Joseph

Jesus Is Born Lesson 1

An Invitation

The children will make invitations to give to friends to invite them to class.

Materials

For each child:

- crayons or markers
- glue stick

For the teacher:

- decorative materials
- utility knife

Reproducible Pages:

- Page D, 1 copy for each child
- Page E, 1 copy for each child

Preparation

1. Cut out the copies of the envelopes and the invitations from the copies of Reproducible Pages D and E.
2. Fold and crease each of the envelopes along the dotted lines and then unfold them. This will help the children to fold them later.
3. Using a utility knife, cut the slit on each envelope.
4. Make a model of the craft following the instructions.

Instructions

1. Show the children the model of the craft and talk with them about how great it would be if they would bring a friend to class to hear about Jesus.
2. Give each child an envelope. Have them fold it at the line under the children's feet. See Figure A.
3. Have each child place glue on the two side flaps and fold them over to form the envelope. See Figure B.
4. Have the children color and decorate the envelopes.
5. Give each child an invitation to color and put into the envelope.
6. Show the children how to insert the tab into the slits on their envelopes.
7. If there is time, have the children further decorate their envelopes.

Conclusion

Talk with the children about who they might invite to class with them.

Teacher Tips

- Share with the children who you are inviting to church.

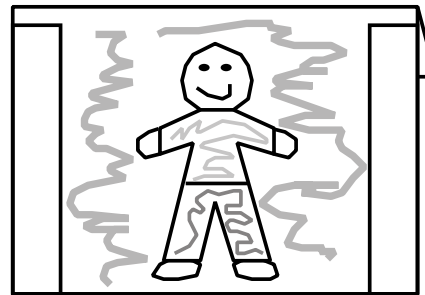

Mary and Joseph

Jesus Is Born Lesson 1



Who Am I?

The children will name different people who were part of the Bible Story.

Materials

For the Teacher:

- scissors
- 2 pieces of construction paper
- glue
- index cards
- crayons or markers
- 1 piece of white paper
- stickers or other small prizes for each child

Reproducible Pages:

- Page C, 1 copy for the teacher

Preparation

1. Cut out and color the pictures from the copy of Reproducible Page C.
2. Glue the pictures onto construction paper.
3. Cut out the pictures leaving a frame of construction paper around them.

Instructions

1. Show the children the cards and explain who each person is: Mary, the mother of Jesus; Joseph, the father of Jesus; baby Jesus; Gabriel, an angel.
2. Explain that you are going to describe someone and the children can guess who it is by choosing the correct card. Each correct answer is worth two points. When the group reaches fourteen points then the whole group will get a prize.
3. Ask the first child a question. If they get it right, write two points on the paper.
4. Continue until each child has had a chance to answer at least one question correctly.

Examples of Questions:

- God sent me to tell Mary that she would be the mother of Jesus. Who am I? (Gabriel, an angel)
- I am God's son, the baby to be born. Who am I? (Jesus)
- I was Jesus' dad on earth. Who am I? (Joseph)
- I was afraid when the angel came to visit me. Who am I? (Mary)
- I was going to marry Mary. Who am I? (Joseph)
- God chose a special name for me. Who am I? (Jesus)
- I am God's messenger and brought good news to Mary and Joseph. Who am I? (Gabriel, an angel)
- God sent me to earth to show you how to obey and love God. Who am I? (Jesus)
- I was Jesus' mommy on earth. Who am I? (Mary)

Conclusion

Have the children use the cards to retell the story.

Teacher Tips

- If the child is hesitant, ask him who he thinks the question is about. If the answer is correct, encourage him to choose the character card. If not, reread the question carefully and ask if someone else can help the child choose the correct character.





Pre class



Mary and Joseph

Jesus Is Born

Lesson 1

Lesson Objectives

- The children will describe Mary and Joseph as parents who loved and obeyed God.
- The children will thank God for sending Jesus.
- The children will discuss different ways to be happy and obedient.

Lesson Text

Luke 1:26-38, Matthew 1:18-25

Scripture Memory Verse

"This is my Son, whom I love; with him I am well pleased."
Matthew 3:17

Nicky Know-It-All

The children will review the story of the angel's visit to Mary and Joseph.

Materials

For the Teacher:

- 2 white socks
- black and white construction paper
- yarn pieces for hair
- 4 cotton balls
- scissors
- white glue

Preparation

1. Cut out four small circles for eyes and glue them onto four cotton balls. Glue the cotton balls onto the foot of each sock as eyes.
2. Glue yarn onto each sock as hair.
3. Cut out two wings from construction paper and staple them onto the leg of one sock making an angel.

Lesson Plan

Greeting and Registration

Preclass Activity: Nicky Know-It-All

Welcome and Singing

Centers:

Game: Who Am I

Craft: An Invitation

Life Application: Whiny or Wise

NOTE: Be sure to allow sufficient time for a snack.

Instructions

Have the children sit in a circle. Bring out the angel and have him fly around to get the children's attention.

GABRIEL: Whee! (flying) Hi Kids! I'm an angel. My name is Gabriel. Do you remember me? (Bring out the Nicky puppet)

NICKY: I remember you. You're the angel my mother uses for the top of the Christmas tree.

GABRIEL: Oh no, no, no, no, no! I am the angel that God sent to announce the birth of his son. Of course, you know the name of God's son.

NICKY: Yes, I know his name is...Jerry!

GABRIEL: Sorry Nick. Can someone help Nicky? That's right. Jesus is the name of God's son. Now Jesus had a mommy and daddy that God asked to take care of Jesus. Who remembers his mommy's name?

NICKY: Oh! Oh! I know! Her name was Pam!

GABRIEL: Kids, Nicky is having trouble remembering. Does someone else have an answer? Right! Mary was her name! Jesus' mom was someone very important. She listened and obeyed God. I'm the angel that explained everything to Mary. But her husband...

NICKY: Oh! Oh! I know his name! It's Joey!

GABRIEL: Shall we help him kids? He's close. What was the name of Mary's husband? Joseph! That's right! He obeyed God too. Now who can tell me what was so special about Jesus?

Let the children respond. Guide the dialogue on how Jesus grew up wanting to please God, his heavenly father; that he is a great example for everyone.

CRAFT

Mary and Joseph

Jesus Is Born Lesson 1

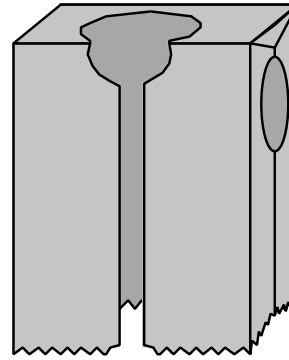
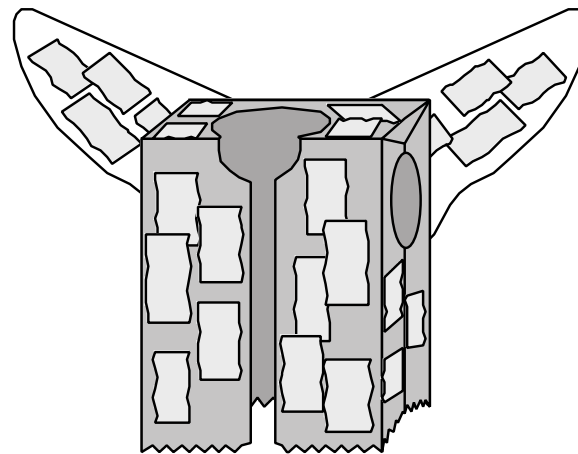

Figure A



Finished Craft



Mary and Joseph

Little Angels

This craft will remind the children of the angel that came to visit Mary and Joseph.

Materials

For each child:

- 1 paper grocery bag
- glue stick
- angel wings from the Preclass Activity

For the Teacher:

- white tissue paper or crepe paper
- scissors
- stapler
- poster board

Preparation

1. Prepare a "coat" for each child as shown in Figure A:
 - A. Turn the bag upside down and cut a hole for the head and neck.
 - B. Cut an opening down the front of the bag.
 - C. On each side of the bag, cut a rounded hole for the arms.
3. Cut or tear the white tissue paper into 5" pieces.
4. Make a model of the craft following the instructions.

Instructions

1. Give each child a paper bag and have them glue the white tissue paper onto the bag.
2. While the children are working help them to staple their wings to the backs of their coats.
3. Have the children cover the wings with pieces of tissue paper.

Conclusion

Have the children put on their coats and pretend to be the angel that visited Mary and Joseph.

Help the children to understand what it means to be a messenger and how they can make God happy by telling people about Jesus.

Teacher Tips

- The more types of white paper you provide (sparkly, crinkley, shiny, etc.) the more exciting the robe will look.
- To save time, staple the wings onto the paper bag coat before class.
- You may have to use tape in the areas where the stapler will not fit.
- Use white or colored cloth tape to make it look attractive.

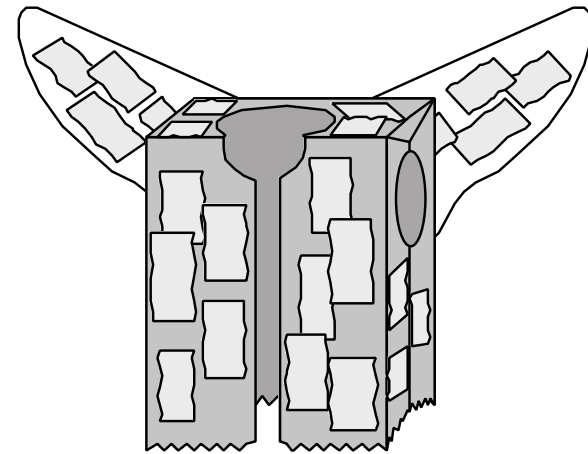

Mary and Joseph

Life
●
A
P
P
L
I
C
A
T
I
O
N
↓



Mary and Joseph

APPLICATION

Whiny or Wise

The children will learn that God is happy when they are happy and do not complain.

Scripture Memory Verse

"This is my Son, whom I love; with him I am well pleased."
Matthew 3:17

Materials

For the Teacher:

- 2 craft sticks
- markers
- glue stick

Reproducible Pages:

- Page B, 1 copy for the teacher

Preparation

1. Cut out and color the puppets from the copy of Reproducible Page B.
2. Glue each puppet onto a craft stick.
3. Familiarize yourself with the scenes.

Instructions

Discuss Mary's happy obedience with the children. Today we are learning about Mary. She didn't grumble or complain when the angel came to visit her. She could have been so disappointed and whiny when the angel came to tell her that she was going to have a baby. Instead she trusted God and was happy. Today Weasel and Owl are going to visit us and I want you to see how they are doing with grumbling and complaining.

Scene 1

OWL: Come on, Weasel, hold my hand while we walk across the street.

WEASEL: (in a very whiny voice) Why should I? I'm big. I don't need to hold your hand.

TEACHER: Do you think Weasel is being like Mary? Why not? How should Weasel answer owl? (Discuss correct responses.)

Scene 2

OWL: Come on, Weasel, Mom said for us to clean our rooms before our friends come over.

WEASEL: (in a very whiny voice) But, I want to finish watching this TV show. I never get to watch TV and I always have to clean my room. Why do we have to keep our rooms so clean?

TEACHER: What do you think about Weasel's answer? How should he act? What should he say? Now let's see how Weasel and Owl are doing playing baseball.

Scene 3

OWL: Hey, Weasel! You're out! That was your third strike!

WEASEL: No, that was a bad pitch. You always make me get out. I never get to be at bat for very long.

OWL: Weasel, you've got to learn to be a good sport and follow the rules.

WEASEL: Why do we have to have all these silly rules? You try to make me strike out all the time.

TEACHER: Do you think Weasel was being a good sport? How should he act when he's playing baseball?

Scripture Memory Activity

Tell the children the memory scripture. Ask the children whom they think the scripture talks about. Discuss the scripture with them. Have the children repeat the scripture with you a few times.

Conclusion

Choose a child to pray and ask God to help the class to be happy and obedient. Have them thank God for the gift of Jesus.

Ask the children with whom they might share what they are learning.

Teacher Tips

- Add any other scenes that may pertain to the cultural and social needs of your congregation.



Mary and Joseph

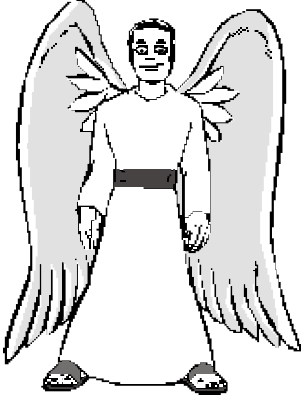

Mary and Joseph

An Angel Visits Mary and Joseph

The children will learn about the birth of Jesus.

Lesson Text

Luke 1:26-38, Matthew 1:18-25

Materials

For the Teacher:

- microphone, real or toy

Preparation

1. Familiarize yourself with the lines.
2. Dress to look the part of a reporter.

Holy Reporting

TEACHER: Good morning. We're here "live" in (your town) talking to the locals about the amazing news from the Bible. An angel of the Lord spoke to Mary and Joseph. Wow! Things are really exciting here. Can you imagine the scene...an angel appears out of nowhere...tells Mary she's going to have a baby—and even tells her what to name the baby. I wonder how she was feeling! Let's get some ideas. (Choose a child to interview.)

TEACHER: Do you think Mary was scared when she heard an angel tell her that she was going to have a baby? (Wait for the child's response).

TEACHER: Really? Why do you think that? (Wait for the child's response.) She wasn't expecting to hear news like that. She had never had a baby before. (Choose another child to interview.)

TEACHER: What do you think you would do if you were Mary? Would you be willing to trust God the way that Mary did? She was scared...but excited to obey God. She was willing to be the mom to a boy named Jesus. Why do you think Joseph and Mary were willing to obey? (Wait for the child's response.) They must have loved and trusted God very much. (Choose another child to interview.)

TEACHER: Hmm...I bet they knew that God wanted Jesus to be born. He was going to help people to learn about God. Does God want us to trust and obey him like Mary did? (Wait for the child's response.) What are some of the ways that we can show God that we love and trust him? (Wait for the child's response.) By obeying our parents and remembering that what God says in the Bible is true. (Choose another child to interview.)

TEACHER: Do you think it was hard to believe that what the angel said was true? (Wait for the child's response.) (Choose another child to interview.)

TEACHER: How does it make you feel that Mary and Joseph did the right thing? (Wait for the child's response.) Very thankful because it means we have Jesus.

TEACHER: How many of you have younger brothers and sisters at home? (Let them raise their hands, and choose a child.)

TEACHER: How did you feel when your little brother and sister was brought home? (Wait for the child's response.) (Choose another child to interview.)

TEACHER: How do you think Mary felt about having a baby? (Wait for the child's response.) (Choose another child to interview.)

TEACHER: What an awesome thing God gave to Mary (and us)...just like a gift. Who likes to get gifts? How do you feel when you get a gift? (Wait for the child's response.) Happy, grateful, lucky, excited, special. (Choose another child to interview.)

TEACHER: Do you think God thinks Jesus is special? Do you think Jesus is special? What makes Jesus special?

TEACHER: Well, what an exciting event we have heard about. I'm sure none of us will ever forget that Mary and Joseph obeyed God and had faith in what he wanted them to do...and we sure are happy about Jesus!!! He really is special.
This is (your name) signing off from (your town).

Teacher Tips

- Write the questions and a few responses on a piece of paper to help you remember, just like a real reporter!



Pre
class

A
C
T
I
V
I
T
Y

Mary and Joseph

Angel Wings

The children will make wings for the Craft Center.

Materials

For each child:

- 1 large piece of poster board
- crayons and or markers
- glue stick
- scissors

For the teacher:

- white paper
- glue
- scissors

Reproducible Pages:

- Page A, 1 copy for the teacher

Preparation

1. Cut out the feather stencil from the copy of Reproducible Page A.
2. Trace and cut out four feathers for each child from white paper.
3. Using Figure A as a guide, draw and cut out two large wings for each child from poster board.

Instructions

1. Give each child four feathers to color and decorate.
2. Have each child glue their feathers onto the wings.

Conclusion

Explain to the children that they are making wings for the Craft Center. The wings are angel wings and they are going to hear a story about an angel with a special message.

Teacher Tips

- If the class is small have some feathers already glued on the wings.

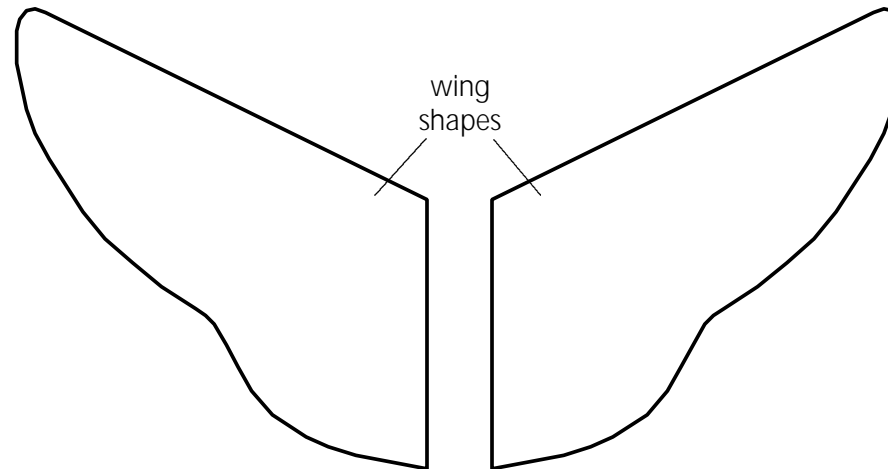

Figure A





Mary and Joseph

Jesus Is Born Lesson 1

Lesson Objectives

- The children will describe Mary and Joseph as parents who loved and obeyed God.
- The children will thank God for sending Jesus.
- The children will discuss different ways to be happy and obedient.

Lesson Text

Luke 1:26-38, Matthew 1:18-25

Scripture Memory Verse

"This is my Son, whom I love; with him I am well pleased."
Matthew 3:17

Lesson Plan

Greeting and Registration

Preclass Activity: Angel Wings

Welcome and Singing

Centers:

Bible Story: An Angel Visits Mary and Joseph

Life Application: Whiny or Wise

Craft: Little Angels

NOTE: Be sure to allow sufficient time for a snack.

